



Dept. of Mech. Eng.
CUET

Published Online March 2015 (<http://www.cuet.ac.bd/merj/index.html>)

Mechanical Engineering Research Journal

Vol. 9, pp. 43–47, 2013

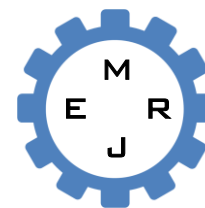

ISSN: 1990-5491

ALTERNATIVE MATERIALS IN HYDRAULIC CYLINDER DESIGN - APPLICATION OF CARBON FIBRE COMPONENTS

J. Ritchie¹, U. Mumtahina², M. G. Rasul³ and A. S. M Sayem^{4*}

¹Graduate, CQ University, Australia

^{2,4}PhD candidate, School of Engineering and Technology, CQ University, Australia

³Associate Professor, CQ University, Australia

Abstract: In today's underground mining industry machinery is constantly getting larger, becoming more robust and more powerful. Therefore it is not surprising that there is a growing requirement for enhanced technologies and ideas to be implemented to make the working environment more efficient whilst maintaining the highest levels of safety. The overall objective of this project was to research hydraulic cylinders, composite materials and manufacturing processes to investigate whether it was feasible to manufacture a hydraulic cylinder from alternative materials namely carbon fibre. The main reasons for completing this project were to reduce the weight of current steel cylinders, prevent or minimize current corrosion rates and to improve safety procedures associated with fitment procedures in the underground mining environment.

Keywords: *Hydraulic cylinder, carbon fibre, mining industry*

1. INTRODUCTION

In underground coal mines one key component that is constantly evolving is Hydraulic Cylinders which are used in many applications along the coal face. These cylinders are currently manufactured from steel which makes them very heavy, difficult to maneuver and also very susceptible to corrosion. This results in dramatically reduced operation life spans and also involves hazardous 'change out' procedures when the cylinders fail.

A hydraulic cylinder is a mechanical component of machinery that converts hydraulic energy into kinetic energy [1]. Hydraulic cylinders are used commonly in many industries such as mining, construction and agriculture to perform a range of different tasks. These devices operate using pressurized liquid which is generally a form of oil to perform a pushing or pulling action in a linear direction. The majority of hydraulic cylinders are manufactured from steel in order to withstand the enormous working pressures at which they operate [2].

The majority of all underground mining hydraulic cylinders are manufactured from 4140 grade steel. This material is used extensively in most industry sectors for a wide range of applications such as axle shafts, bolts, crankshafts,

connection rods, chuck pins, forks, gears, guide rods, hydraulic shafts/components, lathe spindles, pump shafts and sockets [3].

Grade 4140 also has good machinability with practices such as turning, milling, drilling, and thread cutting being completed quite successfully [4]. While this material has been proven successful in the design and manufacture of Hydraulic Cylinders in the underground mining environment, it still possesses a number of disadvantages. These include designs being excessively heavy due to large design safety factors and over engineering which results in the larger models becoming difficult to transport safely. The tough environmental conditions in an underground coal mine also exert harsh working conditions on hydraulic machinery which results in relatively high steel corrosion rates being experienced. This costs both time and money when replacement cylinders are constantly required to be interchanged along the coal face.

According to 'Zoltek', Carbon Fibre can be defined as a long, thin strand of material about 0.005 - 0.010mm in diameter and comprised mostly of carbon atoms [5]. These thin strands of material are extremely strong for their size and when thousands of strands are woven together to form sheets of mesh fabric the overall strength is dramatically increased. These fibre sheets are shaped and molded into particular size groups before

* Corresponding author: Email: yessayem@yahoo.com

being combined with epoxy resins to construct the common composite material that is today known as carbon fibre [5].

Carbon fibre is relatively new in the mining industry with engineers and designers. However in recent times with the growing requirement to improve safety, reduce corrosion and make designs easier to install, the application of carbon fibre technology is experiencing rapid expansion.

In this paper, we try to keep the design as cost effective as possible and to minimize cylinder weight as much as possible whilst still maintaining high levels of design safety and to replace as many existing steel components with carbon fibre as possible whilst still maintaining the structural integrity of the cylinder.

2. METHODOLOGY

2.1 The Prototype Development

The prototype development plan eventuated from a meeting with the manager of D&T Hydraulics who suggested using existing hydraulic cylinder component sizes rather than designing a whole new cylinder. Upon disassembling one of the spare base-lift cylinders in the workshop we decided to draw, manufacture and test both a piston and a gland from carbon fibre materials which is shown Fig. 1. This decision saved substantial time in designing as it allowed the dimensions to be copied from the existing cylinder knowing it had already been designed and engineering to meet both German and Australian Standards [6]. This allowed more time to be allocated to the manufacturing and testing phases of the prototype which was more important to the overall aim of this investigation.



Fig. 1: The existing piston and gland that were used in the prototyping stages of the project.

2.2 Modeling and Detailing

This phase of the methodology involved modeling and detailing both the hydraulic cylinder piston and gland using Pro Engineer software [7]. When the basic block models were created, the more intricate geometrics was created with the use of chamfers, rounds and small extrusions to construct the most realistic representations possible. One particular issue that arose during the modeling phase of this project was drawing the square thread on the outside of the cylinder gland. This particular facet had to be completed using the 'helical sweep' command which took significant time to learn, however the end result achieved was quite accurate. The Figs. 2 and 3 show a three dimensional sectional view and Inline for assembly model of the hydraulic cylinder respectively that were modeled in Pro Engineer.

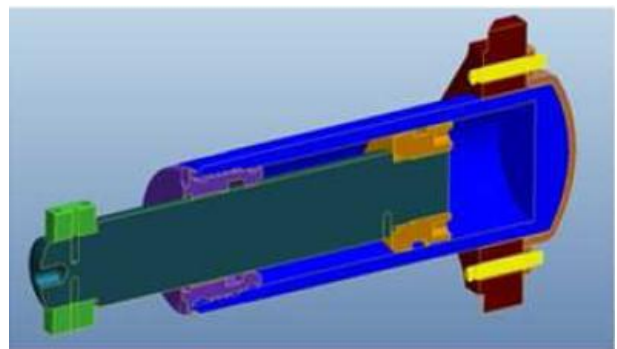

Fig. 2: A sectional view of Hydraulic Cylinder Pro Engineer Model.

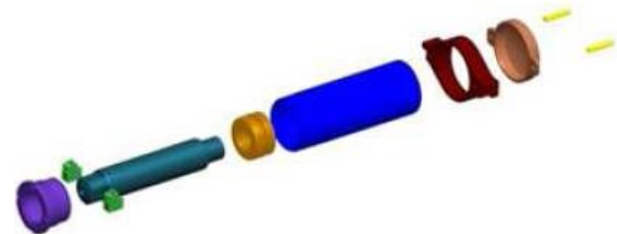

Fig. 3: An inline for assembly view of the Hydraulic Cylinder Pro Engineer Model.

2.3 Piston Finite Element Analysis (FEA)

The first part of completing the FEA analysis was constructing a suitable mesh which is shown in the Fig. 4. It was important to ensure the mesh structure was completely surrounding the piston model and all the triangular shaped nodes were completed with no broken lines which would be indicative of an error [8].

Once the mesh was completed the material specifications for both carbon fibre and steel were inputted and the loads were defined. The load that was applied to the piston was equal to the maximum lifting force achievable on the extension stroke of the ram. This was calculated to be approximately 44 tonne assuming an operating pressure of 350 bar [9]. The next step involved selecting the model's constraint/s which were selected to be the opposing face of the piston which simulated the compressive force being applied. The final step involved executing the simulation run which produced the following

stress and displacement representations shown in Figs. 5 and 6 for both steel and carbon fibre.

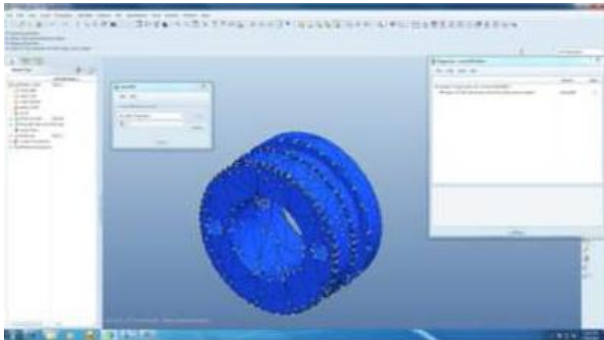

Fig. 4: The FEA Mesh created for Piston analysis

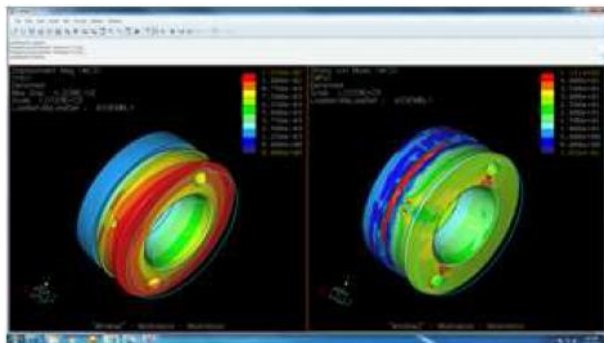

Fig. 5: The displacement and stress representation of the steel piston

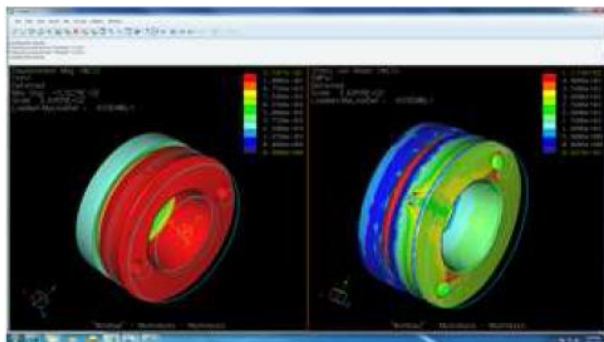

Fig. 6: The displacement and stress representation of the CF piston.

As can be observed from these screenshots both steel and carbon fibre handled the stress in a similar manner however the carbon fibre piston undeniably suffered greater displacement under the given load. The Table 1 further demonstrates the results that were obtained with regard to maximum displacement and stress for both different types of materials during this phase of the methodology.

Table 1 The results of the piston FEA: Steel vs. Carbon fibre.

	Steel	Carbon fibre
Maximum Displacement (mm)	0.0122	0.035
Maximum stress (MPa)	112.1	111.9

2.4 Construction

The construction phase of this project was completed at Machinetek Engineering after a formal risk assessment was completed. Manufacturing the carbon fibre piston prototype occurred according to the following procedure:

- The supplied piece of carbon fibre tube (OD160, ID 60.25mm) was clamped in position and cut with the drop saw to the required lengths.
- The first piece of material was clamped in the 3-jaw chuck and the dimensions from the detail drawing were inputted into the lathe programmed so the cutting process would occur automatically.
- Overall dimensions were cross checked with the drawing and the ‘facing off’ process was commenced. This involved turning down the piston to roughly the required external diameter. This stage of construction can be observed in the Fig. 7.
- The bearing and seal grooves were machined and the inside diameter was machined out so that the internal thread could be cut in the next pass.
- Lathe speed was increased and the M70mm internal thread was cut in three passes with each increment cut being approximately 0.05mm.
- The external scrim layer was removed and the piston was lightly ground to give the edges a better finish especially on the outermost external rounded surface. This step of the process can be observed in Fig. 8.
- The final step in the machining process involved cutting through the tube just to the left of the chuck to allow the piston to be removed from the lathe and be ready for testing.



Fig. 7: The ‘Facing Off’ process in progress at Machinetek Engineering.



Fig.8: The outermost scrim layer being removed at Machinetek Engineering.

3. RESULTS AND DISCUSSION

3.1 Machining Comparison

Upon evaluating and comparing the machinability of carbon fibre compared to that of steel, it is apparent that carbon fibre was irrefutably a more difficult material to machine. This was apparent when the cutting tips quickly wore away when cutting the carbon fibre compared to a much extended lifespan when the tips were used to machine steel. With respect to cutting threads, once again steel far out performed carbon fibre with its ability to accommodate both coarse and fine threads with minimal effort from the machinist. Carbon fibre was found to be very hard to cut threads in and even when they were achieved the finish was ‘grainy’ and appeared brittle to be greatly lacking the strength a steel thread of the same size would possess. However this characteristic wasn’t actually formally tested. Machining carbon fibre was found to be a very messy and hazardous procedure as numerous sharp splinter-like projectiles of fibre and resin were constantly thrown from the lathe. This caused strict hazard prevention measures to be implemented from the risk assessment findings. The overall finish of the carbon fibre prototype was its least favorable trait as the outside surface contained micro tears in the fibres that could be observed via a close inspection. These inconsistencies would mean that high pressure hydraulic oil will possibly leak past the seals which could render the components as useless. Another disappointing observation that was found on the surface of the carbon fibre prototypes were traces of loose fibres that were easily able to be dislodged whilst handling with gloves. This could cause a devastating effect to a hydraulic system by contaminating the oil supply with loose broken fibres that would unquestionably have the potential to block up control valves and other expensive equipment within a hydraulic system.

Table 2 The results of the machining comparison test

Date	Test Number	Location	
9 th February, 2012	1	Machinetek Engineering	
	Machinability (low, medium, high)	Thread Cutting/ Drilling ability (low, medium, high)	Overall Finish (low, medium, high)
4140 Grade Steel	High	High	High
USG 2503 Carbon Fibre	Medium	Medium	Low

3.2 Corrosion Testing

After analysing the results from the corrosion resistance test that was completed it was evident that the carbon fibre material definitely performed better than steel. The two materials were subjected to a simulation of the same harsh

working conditions experienced in an underground coal mine. The results found that carbon fibre was completed unaffected by the coal/water mixture compared to significant surface rust being accumulated on the steel component. This showed that in terms of corrosion resistance in an underground mining environment, carbon fibre is undeniably a better alternative to steel. While the results from this test were quite conclusive it was important to remember that under normal working conditions many of the steel components function inside the hydraulic cylinder and are fully surrounded by oil. This prevents rust corroding them. In saying this, the outside casing of the cylinder is still very susceptible to suffering heavy corrosion over time.

Table 3 The results of the corrosion test

	Testing Environment	Testing Time Period	Observable Corrosion
4140 Grade Steel	Coal Slurry Tray	168 hours	Heavy surface rust
USG 2503 Carbon Fibre	Coal Slurry Tray	168 hours	None

3.3 Weight Comparison Testing

The weight comparison testing that was completed was purely in a theoretical sense using a known volume and density to calculate the mass of both the prototype gland and piston. The results that were obtained show that both the carbon fibre piston and gland were approximately 48.7% less than that of weight of the original steel components. This was quite a successful result as one of the main objectives of this project was to reduce the weight of hydraulic cylinders to make them easier and safer to maneuver to and from the coal face.

Table 4 The results of the corrosion test

	Density (kg/m ³)	Piston Weight (kg)	Gland Weight (kg)
4140 Grade Steel	7210	3.98	3.94
USG 2503 Carbon Fibre	4010	2.04	2.02

3.4 Hardness Testing

From the Brinell hardness tests that were completed it was concluded that USG 2503 carbon fibre was only approximately 26% of the hardness of 4140 grade steel. From the results that were obtained during the Brinell hardness testing it is clear that grade 4140 steel outperformed USG 2503 carbon fibre. Not only did carbon fibre only prove to be just over 26% of the hardness of steel, but it also fractured slightly around the location where the force was applied each test. Initially, before the 1000 kg force was decided upon to complete the test, a 3000 kg force was applied to both the carbon fibre and steel to observe the results. The carbon fibre quickly began to compress and actually cracked quite substantially under this approximate stress of 375 MPa. In comparison the steel specimen dented slightly however it held its shape and didn’t fracture. The

overall conclusions for hardness testing found that steel is still a better material for hydraulic cylinder design due to the nature of the harsh working environment where substantial material hardness is quite essential.

Table 5 Hardness test one

Trial Number	USG 2503 Carbon Fibre Indentation Diameter (d, mm)	4140 Grade Steel Indentation Diameter (d, mm)
1	3.9	2.2
2	3.8	2.15
3	3.75	2.20
Average	3.82	2.18

Table 6 Hardness test two

Trial Number	USG 2503 Carbon Fibre Indentation Diameter (d, mm)	4140 Grade Steel Indentation Diameter (d, mm)
1	4.5	2.2
2	4.4	2.1
3	4.35	2.15
Average	4.42	2.15

Table 7 Hardness test three

Trial Number	USG 2503 Carbon Fibre Indentation Diameter (d, mm)	4140 Grade Steel Indentation Diameter (d, mm)
1	3.95	2.1
2	4.0	2.0
3	3.9	2.0
Average	3.95	2.03

Table 8 Final results of the hardness tests

Test Date	Ball Tip Size (D,mm)	Force applied (P, Newtons)	Average Carbon Fibre Indentation (d,mm)	Average 4140 Grade Steel Indentation (d,mm)
16/2/2012	10	9810	4.06	2.12

4. CONCLUSIONS

With the demand for coal currently very strong and not looking to slow down any time soon, underground mining hydraulic cylinders will continue to develop, becoming larger, more powerful and operating at higher pressures. Therefore it is important to look at using alternative design materials aiming to reduce cylinder weight, improve the safety of underground mine workers and increase cylinder operating life by reducing corrosion.

The conclusions that were drawn after completing the relevant research in the literature review and methodology showed that at this point carbon fibre will not serve as a suitable replacement to steel in hydraulic cylinder design. Although the prototyped carbon fibre piston and gland were lighter than steel and found to be almost completely resistance to corrosion, the components also had a number of

disadvantages. These consisted of carbon fibre being difficult to machine, the surface finish was inconsistent and prevalent to small fragment breaking away which could possibly damage a hydraulic system. The value of Brinell hardness was also only approximately a quarter of the hardness of 4140 grade steel. Therefore it is clear that carbon fibre still has a long way to go before it can enter the hydraulics industry with successful results.

REFERENCES

- [1] T. Dennis, Conversations regarding the design and manufacture of hydraulic cylinders', D&T Hydraulics, 20th June 2011 – 5th November, 2011.
- [2] R. Total Design Engineering, 2011, 'Hydraulic Cylinder Pro Engineer Internal Database – 'Hydraulic Cylinder Components'.
- [3] A. Interlloy, 4140 High Tensile Steel, Product Data Sheet, 2012. [Online] Available: <http://www.interlloy.com.au/ourproducts/high-tensile-steels/4140-hightensile-steel/Gage> (15th March 2012).
- [4] S. Global Metals, 4140 Chrome Bar Related Specifications and machining, 2012. [Online] Available: http://www.globalmetals.com.au/_pdf/Cromax/Cromax_4140.pdf (20th March 2012).
- [5] W. S. Zoltek, What is Carbon Fibre?, 2012. [Online] Available: <http://www.zoltek.com/carbonfiber/> (8th October, 2012).
- [6] M. A. El Shikha, "Reactive maintenance of hydraulic cylinders in agricultural equipments", in American Society of Agricultural and Biological Engineers Annual International Meeting (1-61567-362-8, 978-1-61567-362-9), pp. 1453, 2009.
- [7] T. Hertzberb, "Dangers relating to fires in carbon fibre based composite materials", SP Swedish National Testing & Research Institute, published 12th January 2005.
- [8] Tomasz benarek, "Practical fatigue analysis of hydraulic cylinder –Part II, damage mechanics approach", Institute of Fundamental Technological Research, 24th February 2010.
- [9] E. Zhou, J. Li, J. Lin, "Finite element analysis of piston seals property of hydraulic cylinders", Run Hua Yu Mi Feng/Lubrication Engineering, n-4, pp. 84–85, 2006; Language: Chinese; ISSN: 02540150